

रोल नं.

--	--	--	--	--	--	--	--

Roll No.

परीक्षार्थी कोड को उत्तर-पुस्तिका के मुख-पृष्ठ पर अवश्य लिखें ।

Candidates must write the Code on the title page of the answer-book.

- कृपया जाँच कर लें कि इस प्रश्न-पत्र में मुद्रित पृष्ठ 19 हैं ।
- प्रश्न-पत्र में दाहिने हाथ की ओर दिए गए कोड नम्बर को छात्र उत्तर-पुस्तिका के मुख-पृष्ठ पर लिखें ।
- कृपया जाँच कर लें कि इस प्रश्न-पत्र में 26 प्रश्न हैं ।
- कृपया प्रश्न का उत्तर लिखना शुरू करने से पहले, प्रश्न का क्रमांक अवश्य लिखें ।
- इस प्रश्न-पत्र को पढ़ने के लिए 15 मिनट का समय दिया गया है । प्रश्न-पत्र का वितरण पूर्वाह्न में 10.15 बजे किया जाएगा । 10.15 बजे से 10.30 बजे तक छात्र केवल प्रश्न-पत्र को पढ़ेंगे और इस अवधि के दौरान वे उत्तर-पुस्तिका पर कोई उत्तर नहीं लिखेंगे ।
- Please check that this question paper contains 19 printed pages.
- Code number given on the right hand side of the question paper should be written on the title page of the answer-book by the candidate.
- Please check that this question paper contains 26 questions.
- **Please write down the Serial Number of the question before attempting it.**
- 15 minute time has been allotted to read this question paper. The question paper will be distributed at 10.15 a.m. From 10.15 a.m. to 10.30 a.m., the students will read the question paper only and will not write any answer on the answer-book during this period.

भौतिक विज्ञान (सैद्धान्तिक)

PHYSICS (Theory)

निर्धारित समय : 3 घण्टे

अधिकतम अंक : 70

Time allowed : 3 hours

Maximum Marks : 70

55/3/MT

1

P.T.O.



सामान्य निर्देश :

- (i) सभी प्रश्न अनिवार्य हैं। इस प्रश्न-पत्र में कुल 26 प्रश्न हैं।
- (ii) इस प्रश्न-पत्र के 5 भाग हैं : खण्ड अ, खण्ड ब, खण्ड स, खण्ड द और खण्ड य।
- (iii) खण्ड अ में 5 प्रश्न हैं, प्रत्येक का 1 अंक है। खण्ड ब में 5 प्रश्न हैं, प्रत्येक के 2 अंक हैं। खण्ड स में 12 प्रश्न हैं, प्रत्येक के 3 अंक हैं। खण्ड द में 4 अंक का एक मूल्याधारित प्रश्न है और खण्ड य में 3 प्रश्न हैं, प्रत्येक के 5 अंक हैं।
- (iv) प्रश्न-पत्र में समग्र पर कोई विकल्प नहीं है। तथापि, दो अंकों वाले एक प्रश्न में, तीन अंकों वाले एक प्रश्न में और पाँच अंकों वाले तीनों प्रश्नों में आन्तरिक चयन प्रदान किया गया है। ऐसे प्रश्नों में आपको दिए गए चयन में से केवल एक प्रश्न ही करना है।
- (v) जहाँ आवश्यक हो आप निम्नलिखित भौतिक नियतांकों के मानों का उपयोग कर सकते हैं :

$$c = 3 \times 10^8 \text{ m/s}$$

$$h = 6.63 \times 10^{-34} \text{ Js}$$

$$e = 1.6 \times 10^{-19} \text{ C}$$

$$\mu_0 = 4\pi \times 10^{-7} \text{ T m A}^{-1}$$

$$\epsilon_0 = 8.854 \times 10^{-12} \text{ C}^2 \text{ N}^{-1} \text{ m}^{-2}$$

$$\frac{1}{4\pi\epsilon_0} = 9 \times 10^9 \text{ N m}^2 \text{ C}^{-2}$$

$$m_e = 9.1 \times 10^{-31} \text{ kg}$$

$$\text{न्यूट्रॉन का द्रव्यमान} = 1.675 \times 10^{-27} \text{ kg}$$

$$\text{प्रोटॉन का द्रव्यमान} = 1.673 \times 10^{-27} \text{ kg}$$

$$\text{आवोगाद्रो संख्या} = 6.023 \times 10^{23} \text{ प्रति ग्राम मोल}$$

$$\text{बोल्ट्ज़मान नियतांक} = 1.38 \times 10^{-23} \text{ JK}^{-1}$$



General Instructions :

- (i) **All** questions are compulsory. There are **26** questions in all.
- (ii) This question paper has **five** sections : Section A, Section B, Section C, Section D and Section E.
- (iii) Section A contains **five** questions of **one** mark each, Section B contains **five** questions of **two** marks each, Section C contains **twelve** questions of **three** marks each, Section D contains one value based question of **four** marks and Section E contains **three** questions of **five** marks each.
- (iv) There is no overall choice. However, an internal choice has been provided in one question of two marks, one question of three marks and all the three questions of five marks weightage. You have to attempt only one of the choices in such questions.
- (v) You may use the following values of physical constants wherever necessary :

$$c = 3 \times 10^8 \text{ m/s}$$

$$h = 6.63 \times 10^{-34} \text{ Js}$$

$$e = 1.6 \times 10^{-19} \text{ C}$$

$$\mu_0 = 4\pi \times 10^{-7} \text{ T m A}^{-1}$$

$$\epsilon_0 = 8.854 \times 10^{-12} \text{ C}^2 \text{ N}^{-1} \text{ m}^{-2}$$

$$\frac{1}{4\pi\epsilon_0} = 9 \times 10^9 \text{ N m}^2 \text{ C}^{-2}$$

$$m_e = 9.1 \times 10^{-31} \text{ kg}$$

$$\text{Mass of neutron} = 1.675 \times 10^{-27} \text{ kg}$$

$$\text{Mass of proton} = 1.673 \times 10^{-27} \text{ kg}$$

$$\text{Avogadro's number} = 6.023 \times 10^{23} \text{ per gram mole}$$

$$\text{Boltzmann constant} = 1.38 \times 10^{-23} \text{ JK}^{-1}$$



खण्ड अ
SECTION A

1. 'वाटहीन धारा' पद को परिभाषित कीजिए । 1
Define the term 'wattless current'.

2. संचार व्यवस्था में पुनरावर्तकों का उपयोग क्यों होता है ? 1
Why are repeaters used in communication system ?

3. दो सर्वसम (एक-से) किन्तु भिन्न पदार्थों के चालक A तथा B के लिए I – V ग्राफ (आलेख) यहाँ दर्शाए गए हैं । इन दोनों में से किस चालक की प्रतिरोधकता अधिक है ? 1

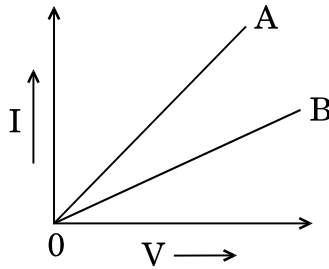

I – V graph for two identical conductors of different materials A and B is shown in the figure. Which one of the two has higher resistivity ?

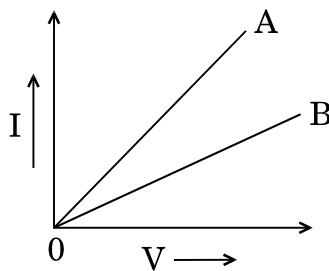

4. दो धनात्मक आवेश एक-दूसरे से कुछ दूरी पर स्थित हैं । इनके कारण विद्युत्-क्षेत्र रेखाओं का चित्रण कीजिए । 1

Depict the electric field lines due to two positive charges kept a certain distance apart.

5. यहाँ किरण आरेख में रेखा AB एक लेंस को निरूपित करती है। बताइए कि यह लेंस उत्तल है या अवतल।

1

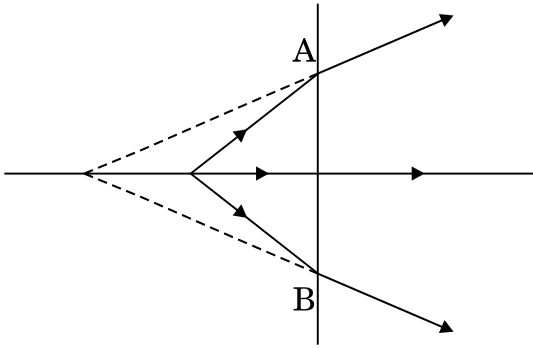

The line AB in the ray diagram represents a lens. State whether the lens is convex or concave.

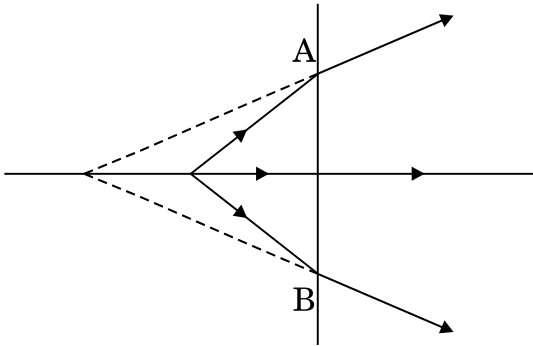

खण्ड ब

SECTION B

6. यहाँ दर्शाए गए परिपथ आरेख में, AB एकसमान मोटाई तथा 1 m लम्बाई का एक तार है और इसका प्रतिरोध 15Ω है। यह तार 2 V विद्युत्-वाहक बल (ई.एम.एफ.) तथा नगण्य आन्तरिक प्रतिरोध के एक सेल E_1 तथा एक प्रतिरोध R से जुड़ा है। एक अन्य सेल E_2 के लिए संतुलन बिन्दु, सिरे A से 30 cm दूरी पर प्राप्त होता है। यदि सेल E_2 का विद्युत्-वाहक बल (ई.एम.एफ.) 75 mV है, तो प्रतिरोध R का मान ज्ञात कीजिए।

2

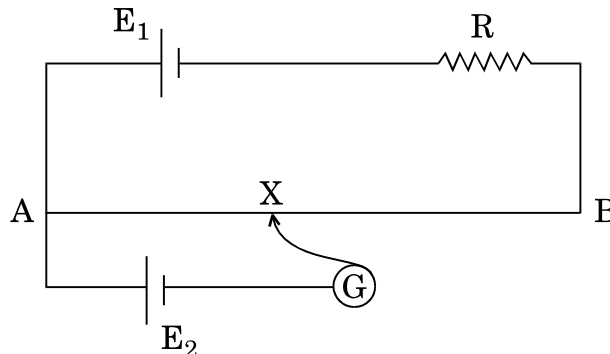

In the circuit diagram shown, AB is a uniform wire of resistance 15Ω and length 1 m. It is connected to a cell E_1 of emf 2 V and negligible internal resistance and a resistance R. The balance point with another cell E_2 of emf 75 mV is found at 30 cm from end A. Calculate the value of the resistance R.

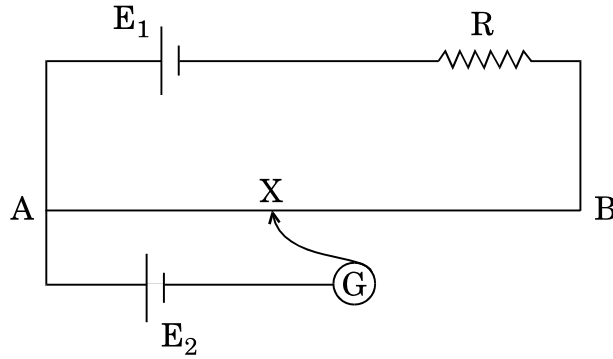

7. आयाम माडुलित किसी तरंग का अधिकतम आयाम 10 V तथा न्यूनतम आयाम 2 V है । माडुलन सूचकांक μ का मान ज्ञात कीजिए । यदि न्यूनतम आयाम शून्य वोल्ट हो, तो μ का मान क्या होगा ? μ के मान को सामान्यतः एक (1) से कम क्यों रखा जाता है ?

2

For an amplitude modulated wave, the maximum amplitude is found to be 10 V while the minimum amplitude is 2 V. Determine the value of modulation index μ .

What would be the value of μ if the minimum amplitude is zero volt ? Why is μ generally kept less than 1 ?

8. काँच के एक प्रिज़्म का कोण 'A' है । इसके एक फलक पर आपतित प्रकाश की एक किरण का आपतन कोण $2A$ है । प्रिज़्म से अपवर्तित किरण उसके विपरीत फलक से टकराती है जो रजतित (चमकीला) है । इससे परावर्तित किरण उसी मार्ग पर वापस चली जाती है । इस परिघटना के लिए किरण आरेख बनाइए तथा प्रिज़्म के पदार्थ के अपवर्तनांक तथा प्रिज़्म के कोण के बीच सम्बन्ध ज्ञात कीजिए ।

2

अथवा

30 cm फोकस दूरी के उत्तल लेंस से एक वस्तु 40 cm दूर रखी है । यदि उत्तल लेंस तथा प्रतिबिम्ब के बीच 50 cm फोकस दूरी का अवतल लेंस इस उत्तल लेंस से 20 cm दूरी पर रख दिया जाता है, तो इससे प्रतिबिम्ब की स्थिति में परिवर्तन ज्ञात कीजिए ।

2

A ray of light incident on one of the faces of a glass prism of angle 'A' has angle of incidence $2A$. The refracted ray in the prism strikes the opposite face which is silvered, the reflected ray from it retracing its path. Trace the ray diagram and find the relation between the refractive index of the material of the prism and the angle of the prism.

OR

An object is placed 40 cm from a convex lens of focal length 30 cm. If a concave lens of focal length 50 cm is introduced between the convex lens and the image formed such that it is 20 cm from the convex lens, find the change in the position of the image.

9. ड्यूटरॉनों तथा α -कणों को समान विभव द्वारा त्वरित किया जाता है। इन दोनों से सम्बद्ध दे ब्रॉग्ली तरंगदैर्घ्यों में अनुपात ज्ञात कीजिए।

2

Deuterons and α -particles are accelerated through the same potential. Find the ratio of the associated de Broglie wavelengths of the two.

10. नीचे दिए गए आरेख में किसी परमाणु के ऊर्जा स्तर दर्शाए गए हैं।

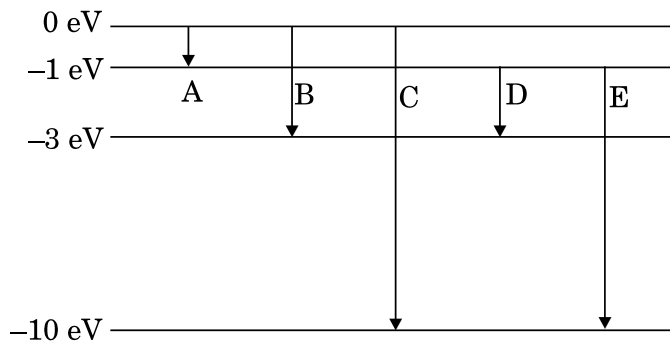

इनमें से कौन-से संक्रमण लाइमन तथा बामर श्रेणियों के लिए हैं ? लाइमन तथा बामर श्रेणियों की न्यूनतम तरंगदैर्घ्यों का अनुपात परिकलित कीजिए।

2

The energy levels of an atom are given below in the diagram.

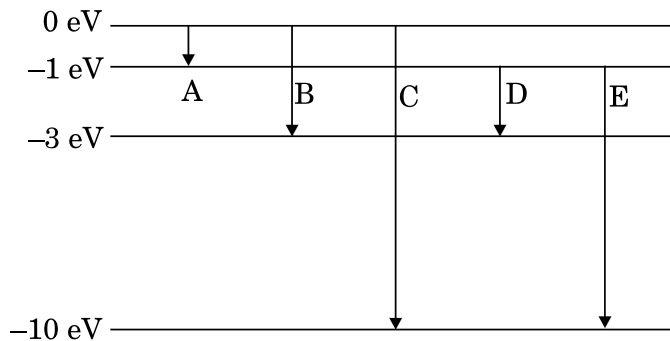

Which of the transitions belong to Lyman and Balmer series ? Calculate the ratio of the shortest wavelengths of the Lyman and the Balmer series of the spectra.



खण्ड स

SECTION C

11. 100Ω के एक प्रतिरोधक तथा $100/\pi \mu\text{F}$ के एक संधारित्र को 220 V, 50 Hz की ए.सी. (a.c.) सप्लाई से जोड़ा गया है।

(a) परिपथ में विद्युत् धारा के मान का परिकलन कीजिए।

(b) प्रतिरोधक तथा संधारित्र के सिरों के बीच (rms) वोल्टता के मान का परिकलन कीजिए। क्या इन दोनों वोल्टताओं का बीजगणितीय योगफल, स्रोत की वोल्टता से अधिक है? यदि हाँ, तो आप इस विरोधाभास का समाधान कैसे करेंगे?

3

A resistor of 100Ω and a capacitor of $100/\pi \mu\text{F}$ are connected in series to a 220 V, 50 Hz a.c. supply.

(a) Calculate the current in the circuit.

(b) Calculate the (rms) voltage across the resistor and the capacitor. Do you find the algebraic sum of these voltages more than the source voltage? If yes, how do you resolve the paradox?

12. किसी धात्विक चालक के सिरों के बीच V विभव आरोपित करने पर अपवाह की परिघटना कैसे घटित होती है, संक्षेप में स्पष्ट कीजिए। इससे आवेश वाहकों के 'अपवाह वेग' पद को परिभाषित कीजिए और दर्शाइए कि धारा घनत्व \vec{j} तथा अनुप्रयुक्त विद्युत्-क्षेत्र \vec{E} के बीच निम्नलिखित सम्बन्ध है :

$$\vec{j} = \sigma \vec{E},$$

जहाँ σ पदार्थ की चालकता को परिभाषित करता है।

3

When a metallic conductor is subjected to a certain potential V across its ends, discuss briefly how the phenomenon of drift occurs. Hence define the term 'drift velocity' of charge carriers and show that the current density \vec{j} is related to the applied electric field \vec{E} by the relation

$$\vec{j} = \sigma \vec{E},$$

where σ defines the conductivity of the material.



13. किसी n-p-n ट्रांज़िस्टर के उभयनिष्ठ उत्सर्जक विन्यास में निवेश तथा निर्गत अभिलक्षणों का अध्ययन करने के लिए परिपथ आरेख बनाइए। संक्षेप में स्पष्ट कीजिए कि इस व्यवस्था का उपयोग, किसी ट्रांज़िस्टर के प्ररूपी निवेश/निर्गत अभिलाक्षणिक वक्र प्राप्त करने के लिए कैसे किया जाता है। निवेश/निर्गत वक्रों की प्रकृति को दर्शाने के लिए ग्राफ़ बनाइए।

3

अथवा

पूर्ण तरंग दिष्टकारी का एक नामांकित परिपथ आरेख बनाइए। इसमें प्रयुक्त (अधःशायी) सिद्धान्त तथा इसकी कार्यविधि को समझाइए। निवेश तथा निर्गत तरंगरूपों को दर्शाइए।

निस्स्यंदन (फिल्टरिंग) में संधारित्र की भूमिका का संक्षेप में वर्णन कीजिए।

3

Draw a circuit diagram to study the input and output characteristics of an n-p-n transistor in common emitter configuration. Explain briefly how this arrangement is used to obtain the typical input/output characteristics of a transistor. Draw the graphs showing the nature of input/output curves.

OR

Draw a labelled circuit diagram of a full wave rectifier. Explain its underlying principle and working. Depict the input and output waveforms.

Describe briefly the role of a capacitor in filtering.

14. साइक्लोट्रॉन का व्यवस्था रेखाचित्र बनाइए। इसका कार्यकारी सिद्धान्त स्पष्ट कीजिए। इस मशीन का उपयोग आवेशित कणों को त्वरित करने में कैसे होता है, यह दर्शाने के लिए आवश्यक गणितीय व्यंजक प्राप्त कीजिए।

3

Draw a schematic sketch of a cyclotron. Explain its working principle. Obtain the necessary mathematical expression to show how this machine is used to accelerate charged particles.



15. दो एकवर्णी तरंगों

$$y_1 = a \cos \omega t, \quad y_2 = a \cos (\omega t + \phi)$$

के अध्यारोपण के कारण किसी बिन्दु पर परिणामी तीव्रता के लिए व्यंजक लिखिए, जहाँ ϕ दो तरंगों के बीच कलान्तर है और a तथा ω क्रमशः उनके आयाम तथा कोणीय आवृत्ति हैं।

यंग के एक द्वि-झिरी प्रयोग में, λ तरंगदैर्घ्य के एकवर्णी प्रकाश का उपयोग किया जाता है। पर्दे के एक बिन्दु पर, जहाँ पथान्तर λ है, प्रकाश की तीव्रता k इकाई है। पर्दे के उस बिन्दु पर तीव्रता ज्ञात कीजिए, जहाँ पर पथान्तर $\lambda/4$ है।

3

Write the expression for the resultant intensity at a point due to the superposition of two monochromatic waves

$$y_1 = a \cos \omega t, \quad y_2 = a \cos (\omega t + \phi)$$

where ϕ is the phase difference between the two waves and a and ω denote the amplitude and angular frequency.

In Young's double slit experiment using monochromatic light of wavelength λ , the intensity of light at a point on the screen where path difference is λ is k units. Find the intensity at a point on the screen where path difference is $\lambda/4$.

16. कल्पना कीजिए कि आपको श्रव्य (ऑडियो) आवृत्ति परास में एक इलेक्ट्रॉनिक संकेत को सीधे दूर स्थित किसी स्थान तक प्रसारित करना है। इस सम्बन्ध में तीन प्रमुख कारकों का संक्षेप में वर्णन कीजिए जो आपके इस कार्य में रुकावट डालते हैं तथा स्पष्ट कीजिए कि इन कारकों को आप कैसे दूर करेंगे ?

3

Suppose you wish to transmit an electronic signal in the audio frequency range over a long distance directly. Write briefly the three important factors which prevent you from doing so and explain how you overcome these factors.



17. 600 pF के एक संधारित्र को 200 V की सप्लाई से आवेशित किया जाता है। फिर इसको सप्लाई से हटाकर 300 pF के एक अन्य अनावेशित संधारित्र से जोड़ दिया जाता है। इस प्रक्रिया में स्थिर-वैद्युत ऊर्जा की कितनी हानि हुई, परिकलन कीजिए। ऊर्जा की इस हानि का स्रोत (कारण) क्या है ?

3

A 600 pF capacitor is charged by a 200 V supply. It is then disconnected from the supply and is connected to another uncharged 300 pF capacitor. Calculate how much electrostatic energy is lost in the process. What is the source of energy loss ?

18. निम्नलिखित प्रकार की विद्युत्-चुम्बकीय तरंगों किस प्रकार उत्पन्न होती हैं :

- (i) सूक्ष्म तरंगें
- (ii) अवरक्त तरंगें

उपर्युक्त विद्युत्-चुम्बकीय विकिरणों के दो-दो प्रमुख उपयोग लिखिए।

3

How are the following types of electromagnetic waves produced :

- (i) Microwaves
- (ii) Infra-red waves

Write two important uses of each of the above electromagnetic radiations.

19. p-n संधि डायोड के लिए (i) अग्रदिशिक बायस तथा (ii) पश्चदिशिक बायस में, V – I अभिलाक्षणिक वक्र के अध्ययन के लिए परिपथ व्यवस्था बनाइए। सिलिकन डायोड के लिए प्ररूपी V – I अभिलाक्षणिक वक्र बनाइए।

निम्नलिखित पदों का संक्षेप में वर्णन कीजिए :

- (i) अग्रदिशिक बायस में “अल्पांश वाहक अंतःक्षेपण (इंजेक्शन)”
- (ii) पश्चदिशिक बायस में “भंजन वोल्टता”

3

Draw the circuit arrangement for studying the V – I characteristics of a p-n junction diode (i) in forward bias and (ii) in reverse bias. Draw the typical V – I characteristics of a silicon diode.

Describe briefly the following terms :

- (i) “minority carrier injection” in forward bias
- (ii) “breakdown voltage” in reverse bias



20. (a) आइन्स्टाइन के चित्रण में प्रकाश-विद्युत् उत्सर्जन से सम्बद्ध मूल प्रारम्भिक प्रक्रम का संक्षेप में वर्णन कीजिए ।
- (b) जब किसी प्रकाश-संवेदी पदार्थ पर ν आवृत्ति का प्रकाश पड़ता (किरणित होता) है, तो उत्सर्जित इलेक्ट्रॉनों की अधिकतम चाल को V_{\max} से प्रकट किया जाता है । आवृत्ति ν के साथ V_{\max}^2 के मान में परिवर्तन (विचलन) को आरेख में दर्शाया गया है ।

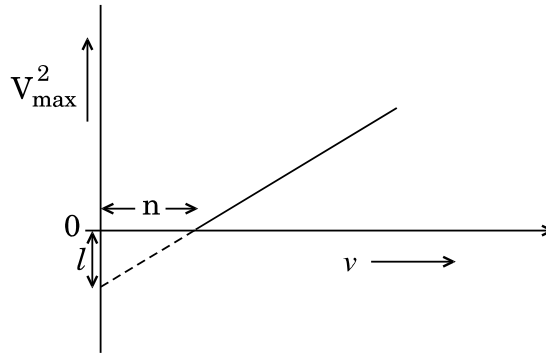

आइन्स्टाइन के प्रकाश-विद्युत् समीकरण के उपयोग से (i) प्लांक स्थिरांक तथा (ii) दिए गए इस प्रकाश-संवेदी पदार्थ के कार्य फलन के लिए व्यंजक, प्राचलों l , n तथा इलेक्ट्रॉन के द्रव्यमान m के पदों में प्राप्त कीजिए ।

3

- (a) Give a brief description of the basic elementary process involved in the photoelectric emission in Einstein's picture.
- (b) When a photosensitive material is irradiated with the light of frequency ν , the maximum speed of electrons is given by V_{\max} . A plot of V_{\max}^2 is found to vary with frequency ν as shown in the figure.

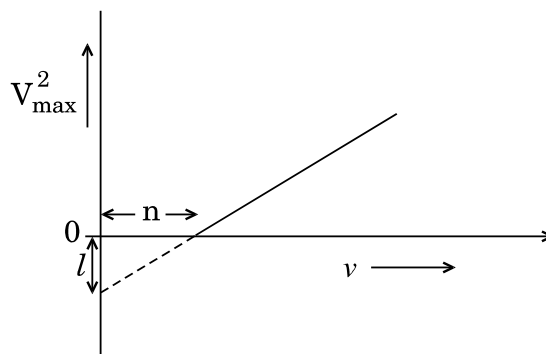

Use Einstein's photoelectric equation to find the expressions for (i) Planck's constant and (ii) work function of the given photosensitive material, in terms of the parameters l , n and mass m of the electron.

21. (a) द्रव्यमान संख्या के फलन के रूप में प्रति न्यूक्लिऑन बंधन ऊर्जा के विचलन (परिवर्तन) को दर्शाने के लिए एक ग्राफ बनाइए। परमाणु द्रव्यमानों के $30 < A < 170$ परिसर में बंधन ऊर्जा प्रति न्यूक्लिऑन का मान व्यावहारिक रूप से नियत रहता है। इस तथ्य की व्याख्या नाभिकीय बलों के कौन-से गुणधर्म द्वारा होती है ?
- (b) किसी रेडियोएक्टिव नाभिक 'A' का क्षय (विघटन) श्रेणीक्रम में निम्नांकित प्रकार से होता है :

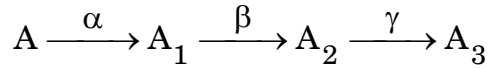

यदि A_3 की द्रव्यमान संख्या तथा परमाणु क्रमांक क्रमशः 176 तथा 69 हैं, तो A की द्रव्यमान संख्या तथा परमाणु क्रमांक ज्ञात कीजिए।

3

- (a) Plot a graph showing the variation of binding energy per nucleon as a function of mass number. Which property of nuclear force explains the approximate constancy of binding energy in the range $30 < A < 170$?
- (b) A radioactive nucleus 'A' undergoes series of decays shown in the following scheme :

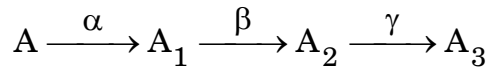

If the mass number and atomic number of A_3 are 176 and 69 respectively, find the mass number and atomic number of A.

22. उपयुक्त आरेख की सहायता से संक्षेप में वर्णन कीजिए कि क्या होता है जब अध्रुवित प्रकाश दो सर्वसम पोलैरोइडों से होकर गुजरता है जिसमें पहला पोलैरोइड अपनी स्थिति में स्थिर रहता है और दूसरे को पहले के सापेक्ष घुमाया जाता है। ध्रुवक तथा विश्लेषक के बीच कोण पर पारगमित प्रकाश की तीव्रता की निर्भरता को दर्शाने के लिए एक ग्राफ बनाइए। स्पष्ट कीजिए कि तीव्रता के इस विचलन (परिवर्तन) को मेलस नियम से कैसे समझा जा सकता है।

3

Discuss briefly, with the help of a suitable diagram, what happens when unpolarised light passes through two identical polaroids where the orientation of one polaroid is fixed and the second is rotated with respect to the one. Draw a graph showing the dependence of intensity of transmitted light on the angle between the polariser and analyser. Explain clearly how one understands this variation using Malus' law.



SECTION D

23. दीपिका और रुचिका को उनके शिक्षक ने गैल्वेनोमीटर के उपयोग से एक प्रयोग करने को कहा । प्रयोग करने से पूर्व दोनों विद्यार्थी यह जानने को उत्सुक थे कि एक छोटे से बॉक्स के आकार में उन्हें दिए गए गैल्वेनोमीटर के विभिन्न भाग क्या हैं । उन्होंने अपने शिक्षक से गैल्वेनोमीटर को खोलकर देखने की आज्ञा माँगी । शिक्षक ने भी सोचा कि गैल्वेनोमीटर को पूरी कक्षा के सामने खोलना एक अच्छा विचार है । उन्होंने गैल्वेनोमीटर को खोलकर उसकी संरचना तथा कार्यविधि को पूरी कक्षा को समझाया ।

उपर्युक्त पैराग्राफ़ के आधार पर, निम्नलिखित प्रश्नों के उत्तर दीजिए :

4

- आपके विचार से दीपिका, रुचिका व उनके शिक्षक द्वारा किन गुणों का प्रदर्शन किया गया ?
- गैल्वेनोमीटर के कार्य करने के सिद्धान्त को संक्षेप में लिखिए ।
- इसमें प्रयुक्त चुम्बक किस आकार का है और इसे इस आकार का क्यों बनाया गया है ?

Deepika and Ruchika were asked by their teacher to perform an experiment using a galvanometer. Before doing the experiment they were very keen to know the different parts of the galvanometer which was given to them in the form of a small box. They approached the teacher and asked for the permission. The teacher thought it would be a good idea if the galvanometer be opened before the whole class and explained its construction and working to all of them.

Based on the above paragraph, answer the following questions :

- What, in your opinion, were the qualities displayed by Deepika, Ruchika and the teacher ?
- State briefly the working principle of the galvanometer.
- What is the shape of the magnets used and why is it so designed ?



खण्ड य

SECTION E

24. (a) अधिक बड़े व्यास के प्रकाशिक दूरदर्शकों में अभिदृश्यकों का चयन करने में किन दो मुख्य कारकों को ध्यान में रखना चाहिए ?
- (b) किसी परावर्ती दूरदर्शक द्वारा प्रतिबिम्ब का बनना दर्शाने के लिए एक किरण आरेख बनाइए। इसकी आवर्धन क्षमता क्या है ?
- (c) अपवर्ती दूरदर्शक की तुलना में परावर्ती दूरदर्शक के क्या-क्या लाभ हैं ?

5

अथवा

- (a) सामान्य संयोजन में किसी संयुक्त सूक्ष्मदर्शी द्वारा प्रतिबिम्ब का बनना दर्शाने के लिए एक किरण आरेख बनाइए।
- (b) दो बिन्दुओं के बीच के उस न्यूनतम पार्थक्य (दूरी) के लिए एक व्यंजक प्राप्त कीजिए, जिस दूरी पर स्थित इन दोनों बिन्दुओं को एक सूक्ष्मदर्शी सुस्पष्ट देख सके। इस दूरी का विभेदन क्षमता से क्या सम्बन्ध है ? उन कारकों का उल्लेख कीजिए जिनसे किसी सूक्ष्मदर्शी की विभेदन क्षमता में वृद्धि की जा सके।
- (a) State two main considerations taken into account while choosing the objective in optical telescopes with large diameters.
- (b) Draw a ray diagram for the formation of image by a reflecting type telescope. What is its magnifying power ?
- (c) What are the advantages of a reflecting type telescope over the refracting type ?

5

OR

- (a) Draw a ray diagram for the formation of image by a compound microscope in normal adjustment.
- (b) Obtain the expression for the minimum separation between the two points seen as distinct in a microscope. What is its relation with the resolving power ? Mention the factors by which the resolving power of a microscope can be increased.



25. (a) किसी परिनालिका S_2 के सापेक्ष एक अन्य परिनालिका S_1 के अन्योन्य प्रेरकत्व का अर्थ स्पष्ट कीजिए ।
- (b) दो संकेन्द्रित वृत्ताकार कुंडलियों की त्रिज्याएँ क्रमशः r_1 तथा r_2 हैं, जहाँ $r_1 \ll r_2$. इन्हें इस प्रकार समाक्षी रखा गया है कि इनके केन्द्र एक-दूसरे के ऊपर पड़ते हैं । इस व्यवस्था के अन्योन्य प्रेरकत्व के लिए व्यंजक प्राप्त कीजिए ।
- (c) एक प्रयोग व्यवस्था में दो समाक्षी कुंडलियाँ C_1 तथा C_2 एक-दूसरे के समान्तर रखी गई हैं । कुंडली C_2 में विद्युत् धारा I_2 के परिवर्तन के संगत कुंडली C_1 में प्रेरित विद्युत्-वाहक बल (ई.एम.एफ.) के लिए व्यंजक प्राप्त कीजिए, यदि C_1 में तार के फेरों की संख्या N_1 है और C_2 में N_2 है ।

5

अथवा

- (a) ऐम्पियर के परिपथीय नियम का उल्लेख कीजिए । दर्शाइए कि किसी अनन्त, सीधे तथा I धारावाही तार के बाहर उससे r दूरी पर चुम्बकीय क्षेत्र B स्पर्शरिखीय है तथा उसका मान $B = \mu_0 I / (2\pi r)$ होता है ।
- (b) यहाँ आरेख में दर्शाए गए किसी लम्बे सीधे बेलनाकार तार की वृत्ताकार अनुप्रस्थ-काट की त्रिज्या a है । इस तार की अनुप्रस्थ-काट में विद्युत् धारा I एकसमान रूप से वितरित है । इससे $r < a$ तथा $r > a$ क्षेत्र में चुम्बकीय क्षेत्र B के मान का परिकलन कीजिए । तार के केन्द्र से दूरी r तथा B के बीच एक ग्राफ़ बनाइए ।

5

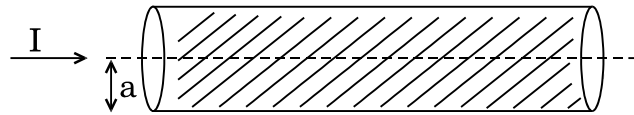

- (a) Explain the meaning of mutual inductance of a solenoid S_1 with respect to the solenoid S_2 .
- (b) Consider two concentric circular coils, one of radius r_1 and the other of larger radius r_2 ($r_1 \ll r_2$), placed coaxially with centres coinciding with each other. Obtain the expression for the mutual inductance of the arrangement.
- (c) In an experimental arrangement of two coils C_1 and C_2 placed coaxially parallel to each other, find out the expression for the emf induced in the coil C_1 (of N_1 turns) corresponding to the change of current I_2 in the coil C_2 (of N_2 turns).

OR



- (a) State Ampere's circuital law. Show that the magnetic field B at a distance r outside the straight infinite wire carrying current I is tangential and is given by $B = \mu_0 I / (2\pi r)$.
- (b) Consider a long straight cylindrical wire of circular cross-section of radius a , as shown in the figure. The current I is uniformly distributed across this cross-section. Calculate the magnetic field B in the region $r < a$ and $r > a$. Plot a graph of B versus r from the centre of the wire.

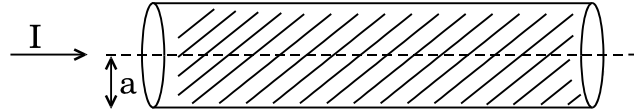

26. एक लम्ब-वृत्तीय बेलन की लम्बाई 'a' तथा त्रिज्या 'r' है। इसका केन्द्र मूल-बिन्दु पर है और इसकी अक्ष, x-अक्ष के अनुदिश है जिससे इसका एक फलक आरेख में दिखाए गए अनुसार, $x = +a/2$ पर तथा दूसरा, $x = -a/2$ पर स्थित है। x-अक्ष के समान्तर एक एकसमान विद्युत्-क्षेत्र इस प्रकार आरोपित है कि $\vec{E} = E_0 \hat{i}$, $x > 0$ के लिए और $\vec{E} = -E_0 \hat{i}$, $x < 0$ के लिए।

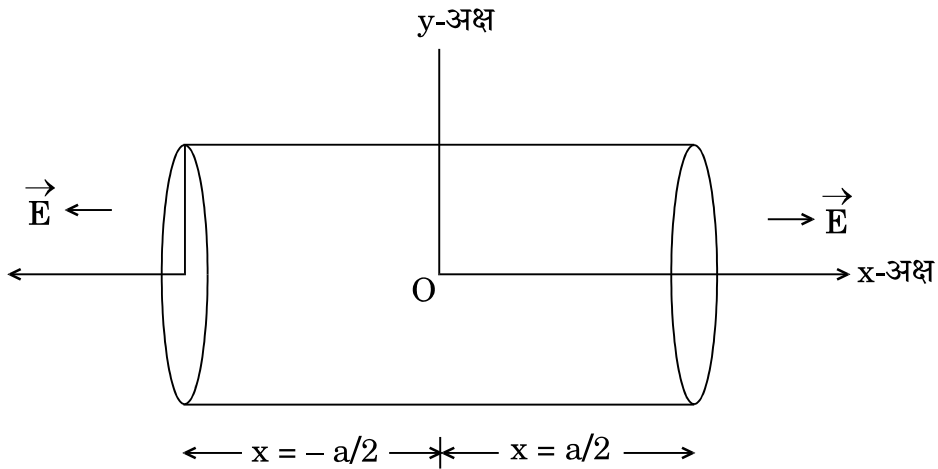

इससे फ्लक्स का मान ज्ञात कीजिए, बेलन के (i) समतल फलकों से होकर जाने वाले, (ii) वक्र पृष्ठ से होकर जाने वाले। बेलन से होकर बाहर की ओर नेट फ्लक्स कितना है तथा बेलन के भीतर नेट आवेश कितना है ?

5

अथवा

- (a) किसी समान्तर पट्टिका संधारित्र के दो बड़े समतल समान्तर चालकों के पृष्ठीय आवेश घनत्व क्रमशः $+\sigma$ तथा $-\sigma$ हैं। ये निर्वात में एक-दूसरे से अल्प दूरी पर स्थित हैं। गाउस नियम के उपयोग से दर्शाइए कि
- दोनों पट्टिकाओं के बाहरी क्षेत्र में विद्युत्-क्षेत्र शून्य है,
 - आवेशित पट्टिकाओं के बीच भीतरी क्षेत्र में विद्युत्-क्षेत्र σ/ϵ_0 है।
- इससे समान्तर पट्टिका संधारित्र की धारिता के लिए व्यंजक प्राप्त कीजिए।
- (b) स्पष्ट कीजिए कि संधारित्र की दो पट्टिकाओं के बीच के स्थान में k परावैद्युतांक की एक परावैद्युत पट्टी डाल देने से निम्नलिखित पर क्या प्रभाव होगा :
- विद्युत्-क्षेत्र पर,
 - संधारित्र की धारिता पर।

5

A right circular cylinder of length 'a' and radius 'r' has its centre at the origin and its axis along the x-axis so that one face is at $x = +a/2$ and the other at $x = -a/2$, as shown in the figure. A uniform electric field is acting parallel to the x-axis such that $\vec{E} = E_0 \hat{i}$ for $x > 0$ and $\vec{E} = -E_0 \hat{i}$ for $x < 0$.

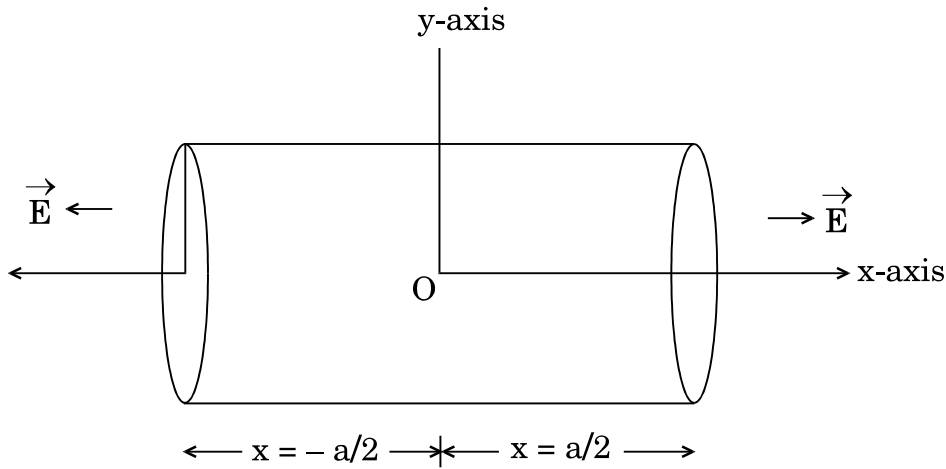

Find out the flux (i) through the flat faces, (ii) through the curved surface of the cylinder. What is the net outward flux through the cylinder and the net charge inside the cylinder ?

OR



(a) Show, using Gauss's law, that for a parallel plate capacitor consisting of two large plane parallel conductors having surface charge densities $+\sigma$ and $-\sigma$, separated by a small distance in vacuum, the electric field

(i) in the outer regions of both the plates is zero,

(ii) is σ/ϵ_0 in the inner region between the charged plates.

Hence obtain the expression for the capacitance of a parallel plate capacitor.

(b) Explain what is the effect of inserting a dielectric slab of dielectric constant k in the intervening space inside the plates on

(i) the electric field,

(ii) the capacitance of the capacitor.

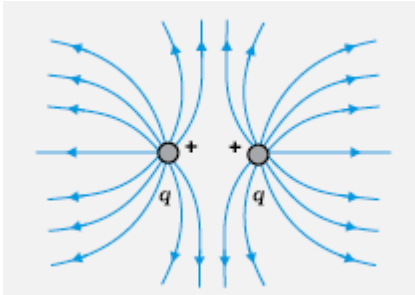

MARKING SCHEME
SET 55/1/MT

Q. No.	Expected Answer / Value Points	Marks	Total Marks				
Section A							
Set1,Q1 Set2,Q5 Set3,Q4	 <p>[Award ½ mark if the student just writes that the field lines radiate outwards from a positive charge]</p>	1	1				
Set1,Q2 Set2,Q4 Set3,Q5	Convex lens OR Converging lens	1	1				
Set1,Q3 Set2,Q2 Set3,Q1	<p>A current is said to be wattless if the average power consumed over one complete cycle is zero.</p> <p>Alternatively, In a a.c. circuit containing pure inductor or pure capacitor the phase difference between voltage and current is $\pi/2$. Hence $\cos \phi = 0$ and no power is dissipated even though a current is flowing in the circuit. This current is referred as wattless current.</p> <p>Alternatively, The component of the current perpendicular to the applied voltage ($I_v \sin \phi$) does not contribute power in an LCR circuit. Hence it is referred as wattless current.</p>	1	1				
Set1,Q4 Set2,Q3 Set3,Q2	Repeaters are used to increase/extend the range of a communication system.	1	1				
Set1,Q5 Set2,Q1 Set3,Q3	B has higher resistivity. Alternatively, B	1	1				
Section B							
Set1,Q6 Set2,Q8 Set3,Q9	<table border="1" style="width: 100%; border-collapse: collapse;"> <tr> <td style="padding: 5px;">Formula</td> <td style="text-align: right; padding: 5px;">$\frac{1}{2}$</td> </tr> <tr> <td style="padding: 5px;">Ratio of the de-Broglie wavelengths</td> <td style="text-align: right; padding: 5px;">$1 \frac{1}{2}$</td> </tr> </table> <p>De-Broglie wavelength $\lambda = \frac{h}{\sqrt{2mqV}}$</p> <p>Ratio of de-Broglie wavelengths of deuterons and α - particle</p>	Formula	$\frac{1}{2}$	Ratio of the de-Broglie wavelengths	$1 \frac{1}{2}$	½	1½
Formula	$\frac{1}{2}$						
Ratio of the de-Broglie wavelengths	$1 \frac{1}{2}$						

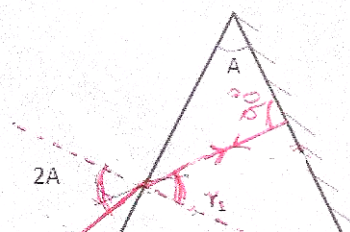
Set1,Q7 Set2,Q9 Set3,Q10	<table border="1" style="width: 100%;"> <tr> <td style="width: 60%;">Identifying the transitions</td> <td style="width: 40%; text-align: right;">1/2 + 1/2</td> </tr> <tr> <td>Calculating the ratio of shortest wavelengths</td> <td style="text-align: right;">1</td> </tr> </table> <p>Lyman series - C and E Blamer Series – B and D</p> <p>Ratio of the shortest wavelength $\frac{\lambda_L}{\lambda_B} = \frac{3}{10} = 0.3$</p> <p>Alternatively</p> <p>Ratio of the shortest wavelength $\frac{\lambda_L}{\lambda_B} = \frac{n_1^2}{n_2^2} = \frac{1}{4}$</p> <p>[<u>Note</u>: The student may write that Lyman and Balmer series are defined for the hydrogen atom and the given energy level values do not correspond to hydrogen. Hence one cannot identify the Lyman and Balmer series in the given case. Full credit may be given for this type of answer]</p>	Identifying the transitions	1/2 + 1/2	Calculating the ratio of shortest wavelengths	1	1/2 1/2 1	2		
Identifying the transitions	1/2 + 1/2								
Calculating the ratio of shortest wavelengths	1								
Set1,Q8 Set2,Q10 Set3,Q7	<table border="1" style="width: 100%;"> <tr> <td style="width: 60%;">Determining the value of modulation Index</td> <td style="width: 40%; text-align: right;">1</td> </tr> <tr> <td>Value of μ when amplitude is zero</td> <td style="text-align: right;">1/2</td> </tr> <tr> <td>Reason for $\mu < 1$</td> <td style="text-align: right;">1/2</td> </tr> </table> $A_c + A_m = 10 V$ $A_c - A_m = 2 V$ <p>On solving we get Modulation Index $\mu = \frac{A_m}{A_c} = \frac{4}{6} = \frac{2}{3}$</p> <p>If the value of minimum amplitude $A_c - A_m = 0, A_c = A_m = 5V$</p> <p>Then $\mu = \frac{A_m}{A_c} = 1$</p> <p>$\mu$ is kept less than one to avoid distortion.</p>	Determining the value of modulation Index	1	Value of μ when amplitude is zero	1/2	Reason for $\mu < 1$	1/2	1/2 1/2 1/2 1/2	2
Determining the value of modulation Index	1								
Value of μ when amplitude is zero	1/2								
Reason for $\mu < 1$	1/2								
Set1,Q9 Set2,Q6 Set3,Q8	<table border="1" style="width: 100%;"> <tr> <td style="width: 60%;">Diagram</td> <td style="width: 40%; text-align: right;">1</td> </tr> <tr> <td>Relation between refractive index and angle of the prism</td> <td style="text-align: right;">1</td> </tr> </table> 	Diagram	1	Relation between refractive index and angle of the prism	1	1			
Diagram	1								
Relation between refractive index and angle of the prism	1								



$$A = r_1$$

$$\text{Refractive index of the material is } \mu = \frac{\sin i}{\sin r} = \frac{\sin 2A}{\sin A} \\ (= 2 \cos A)$$

1/2
1/2

OR

Image for the first lens	1/2
Formula for the second lens and substituting correct values	1/2
Calculating the distance between initial and final positions of the image	1

For convex lens

$$u = -40 \text{ cm}, f = +30 \text{ cm}$$

$$\therefore \frac{1}{30} = \frac{1}{v} - \frac{1}{-40}$$

$$\therefore v = 120 \text{ cm}$$

On introducing concave lens of focal length $f = -50 \text{ cm}$

$$f = -50 \text{ cm}, u = +(120-20) \text{ cm} = +100 \text{ cm}$$

$$\therefore \frac{1}{-50} = \frac{1}{v} - \frac{1}{100}$$

$$\therefore \frac{1}{v} = \frac{1}{100} - \frac{1}{50} = -\frac{1}{100}$$

$$\therefore v = -100 \text{ cm}$$

Change in the position of the image = 200 cm to the left of its original position.

1/2

1/2

1/2

1/2

2

2

Set1,Q10
Set2,Q7
Set3,Q6

Calculation of potential gradient	1
Calculation of unknown resistance R	1

$$\text{Current through the wire } I = \frac{E}{\frac{R+r}{2}} \\ = \frac{E}{R+15}$$

$$\therefore \text{Potential gradient} = \left(\frac{2}{R+15}\right) \times \frac{15}{100}$$

Now $E_2 =$ Potential drop across 30 cm

1/2

1/2

Section C

Set1,Q11 Set2,Q20 Set3,Q17	<table border="1" style="width: 100%; border-collapse: collapse;"> <tr> <td style="padding: 5px;">Formulae</td> <td style="text-align: right; padding: 5px;">1</td> </tr> <tr> <td style="padding: 5px;">Calculating energy loss</td> <td style="text-align: right; padding: 5px;">1 ½</td> </tr> <tr> <td style="padding: 5px;">Source of energy loss</td> <td style="text-align: right; padding: 5px;">½</td> </tr> </table> <p>We have, energy stored = $\frac{1}{2} \frac{Q}{C^2}$ and Equivalent Capacitance = $C_1 + C_2$ $= (600 + 300) \text{ pF}$</p> <p>Charge on the capacitor = $Q = 600 \times 200 \times 10^{-12}$ $= 12 \times 10^{-8} \text{ C}$</p> <p>Initial Energy = $\frac{1}{2} \frac{Q^2}{C} = \frac{1}{2} \frac{Q^2}{600 \times 10^{-12}}$</p> <p>Final Energy = $\frac{1}{2} \frac{Q^2}{900 \times 10^{-12}}$</p> <p>Loss in energy = $\frac{1}{2} \frac{144 \times 10^{-16}}{10^{-12}} \left[\frac{1}{600} - \frac{1}{900} \right]$ $= 4 \times 10^{-6} \text{ J}$</p> <p>The source of energy loss is the energy converted into heat due to sharing of charge between the two capacitors. (Also accept: heat produced) [Alternatively: Also accept if the student calculates directly.]</p>	Formulae	1	Calculating energy loss	1 ½	Source of energy loss	½	½ ½ ½ ½ ½	3
Formulae	1								
Calculating energy loss	1 ½								
Source of energy loss	½								
Set1,Q12 Set2,Q21 Set3,Q18	<table border="1" style="width: 100%; border-collapse: collapse;"> <tr> <td style="padding: 5px;">Production of i) microwaves</td> <td style="text-align: right; padding: 5px;">½</td> </tr> <tr> <td style="padding: 5px;"> ii) infrared waves</td> <td style="text-align: right; padding: 5px;">½</td> </tr> <tr> <td style="padding: 5px;">Two uses of each wave</td> <td style="text-align: right; padding: 5px;">(½+½) × 2</td> </tr> </table> <p>i) Microwaves are produced by special vacuum tubes called Klystrons / Magnetrons / Gun diodes / Point contact diodes. (<u>any one</u>) Uses: Radar system, Ovens, Communication (<u>any two</u>)</p> <p>ii) Infrared waves are produced by vibration of atoms and hot bodies. Uses: Physical therapy, remote switches in household electronic systems, detectors in earth satellites (<u>any two</u>)</p>	Production of i) microwaves	½	ii) infrared waves	½	Two uses of each wave	(½+½) × 2	½ ½ + ½ ½ ½ + ½	3
Production of i) microwaves	½								
ii) infrared waves	½								
Two uses of each wave	(½+½) × 2								
Set1,Q13 Set2,Q22 Set3,Q19	<table border="1" style="width: 100%; border-collapse: collapse;"> <tr> <td style="padding: 5px;">Drawing circuit diagrams of a p - n junction diode in</td> <td></td> </tr> <tr> <td style="padding: 5px;">i) forward bias</td> <td style="text-align: right; padding: 5px;">½</td> </tr> <tr> <td style="padding: 5px;">ii) reverse bias</td> <td style="text-align: right; padding: 5px;">½</td> </tr> </table>	Drawing circuit diagrams of a p - n junction diode in		i) forward bias	½	ii) reverse bias	½		
Drawing circuit diagrams of a p - n junction diode in									
i) forward bias	½								
ii) reverse bias	½								

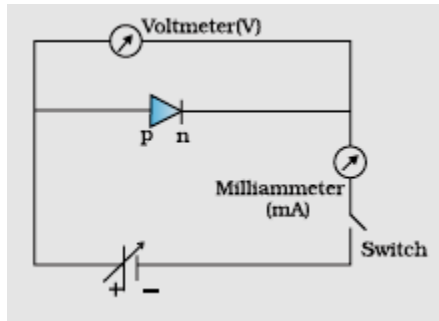

a) Forward bias

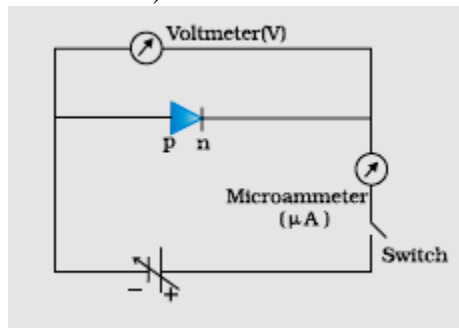

b) Reverse bias

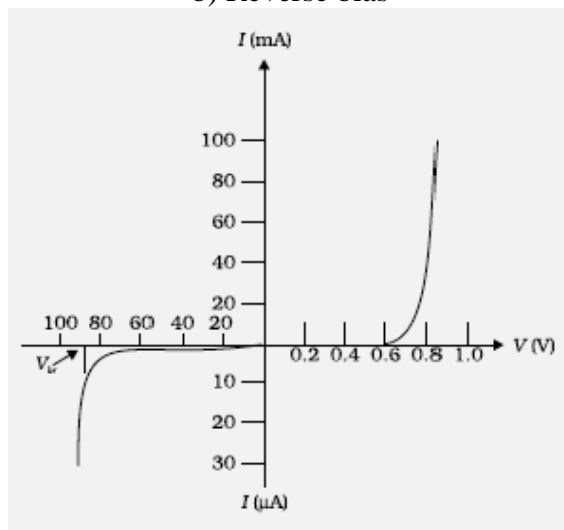

(i) During forward bias majority carriers (electrons) enter from n to p side which are actually minority carriers in p. This is called minority carrier injection.

Alternatively

Majority carriers holes enter from p side and enter into n side

(ii) At very high reverse bias voltage, the current suddenly increases. This voltage is called breakdown voltage.

Alternatively

It is the critical voltage in reverse bias at which current is independent of applied voltage.

1/2

1/2

1

1/2

1/2

(a) According to Einstein, packets of energy called photons, which are absorbed completely by electrons. This absorbed energy is used to eject the electron and also provide kinetic energy to the emitted electron.

(b) i) $\frac{1}{2} m V_{max}^2 = h\nu - \phi_0$

$$\therefore V_{max}^2 = \left(\frac{2h}{m}\right)\nu - \left(\frac{2\phi_0}{m}\right)$$

$$\text{Slope} = \frac{2h}{m} = \frac{l}{n}$$

$$\therefore h = \frac{m l}{2 n}$$

$$\text{Intercept} = \frac{2\phi_0}{m} = l$$

$$\therefore \phi_0 = \frac{m l}{2}$$

1

1/2

1/2

1/2

1/2

3

Set1,Q15
Set2,Q12
Set3,Q13

Drawing circuit diagram	1
Explanation of input / output characteristics	1
Drawing graphs showing input / output characteristics	1

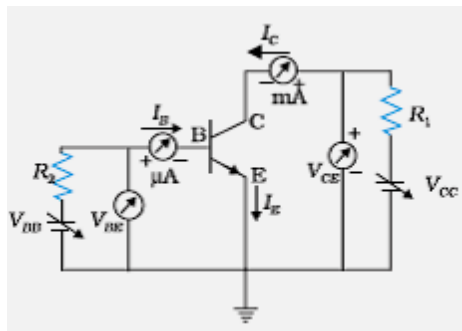

For input characteristics,

Keep V_{CE} as fixed value

Study the dependence of I_B on V_{BE}

For output characteristics,

Keep I_B as constant

Study the dependence of I_C on V_{CE}

(Any one)

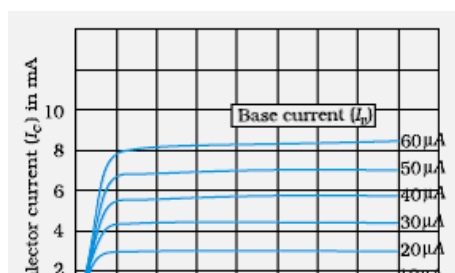
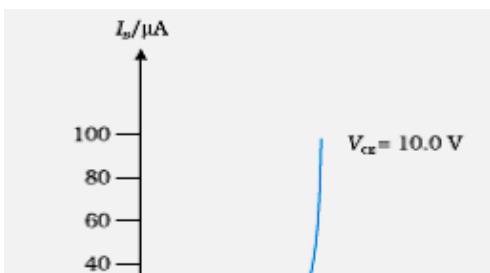

1

1

1

OR

Drawing circuit diagram	1
Principle	1/2
Working	1/2
Input and output waveform	1/2
Role of capacitor	1/2

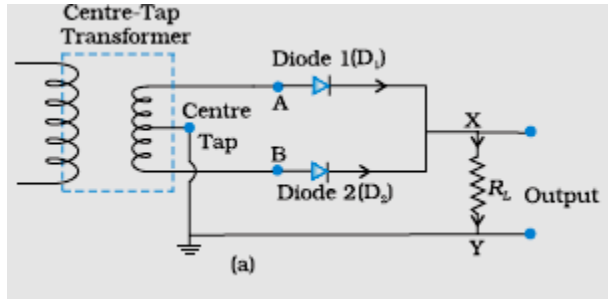

Principle: When the diode is forward biased, it conducts and when it is reverse biased, it does not conduct.

Working: Secondary of the transformer has a center tap. The two diodes conduct during alternate half cycles but the current, in the load, flows in the same direction during both the half cycles.

Input Waveform

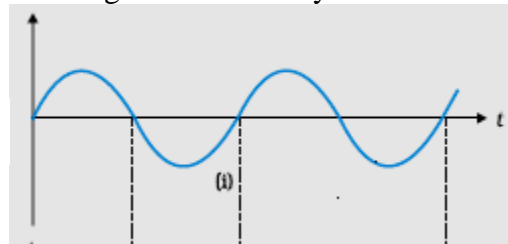

Output Waveform

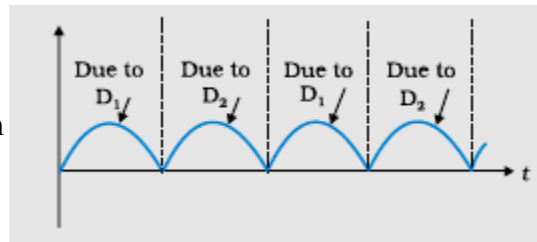

Role of capacitor is to smoothen the output. (also accept any other answer)

Set1,Q16
Set2,Q13
Set3,Q14

Diagram	1
Explanation of working principle	1
Obtaining the mathematical expression	1

1
1/2
1/2
1/2
1/2

3

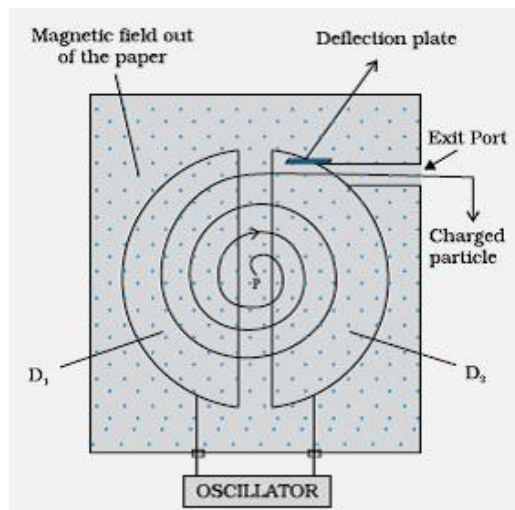

A charged particle can be accelerated to very high energy by subjecting it to an oscillating electric field applied between the dees. When the charged particle is subjected to a uniform magnetic field, it moves in a circular path. Both the fields are perpendicular to each other. The time for one revolution of the charged particle is independent of its speed or radius of its orbit.

$$Bqv = \frac{mv^2}{r}$$

$$v = \frac{Bqr}{m}$$

$$\therefore T = \frac{2\pi r}{v}$$

$$\therefore T = \frac{2\pi m}{Bq}$$

Set1,Q17
Set2,Q16
Set3,Q15

Expression for resultant intensity	1
Finding intensity at the given point on the screen	2

Resultant Intensity

$$I = 4I_o \cos^2\left(\frac{\phi}{2}\right)$$

Alternatively : $I_R = I_o + I_o + 2I_o \cos\phi$

When the path difference is λ , phase difference is 2π

$$\therefore I_R = I_o + I_o + 2I_o$$

$$= 4I_o = K$$

If path difference is $\frac{\lambda}{4}$, phase difference is $\frac{\pi}{2}$

$$\therefore I_R = I_o + I_o + 0$$

$$= 2I_o = \frac{K}{2}$$

Set1,Q18
Set2,Q17

Writing three factors	1 1/2
Explanation to any two of these factors	1 1/2

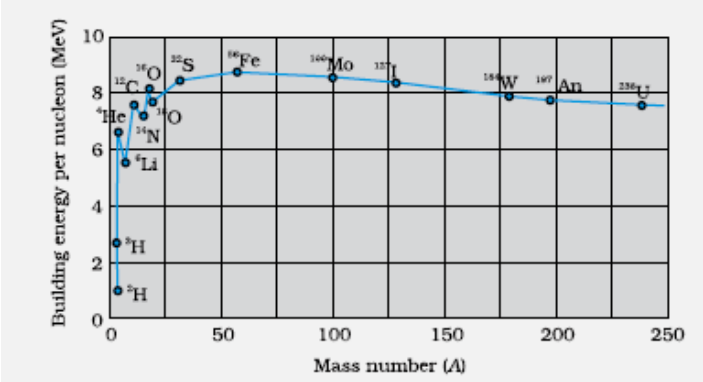

	<p>(iii) Intermixing of signals</p> <p>To overcome these factors</p> <p>(i) Size of antenna should be comparable to wavelength (around $\lambda/4$).</p> <p>(ii) Power depends inversely on λ^2 - Power radiated increases with decrease of wavelength.</p> <p>(iii) Message signal should be used to modulate a high frequency carrier wave so that a band of frequencies can be allotted to each message signal.</p>	<p>1/2</p> <p>1/2</p> <p>1/2</p>	<p>3</p>
--	---	----------------------------------	----------

<p>Set1,Q19</p> <p>Set2,Q18</p> <p>Set3,Q21</p>	<table border="1" data-bbox="170 531 1159 672"> <tr> <td>(a) Binding Energy/nucleon graph</td> <td>1 1/2</td> </tr> <tr> <td>Property</td> <td>1/2</td> </tr> <tr> <td>(b) Finding Atomic number and Mass number of A</td> <td>1</td> </tr> </table> <p>(a)</p>  <p>Nuclear forces are short ranged / saturated (any one)</p> <p>(b) ${}_{70}A^{180} \xrightarrow{\alpha} {}_{68}A_1^{176} \xrightarrow{\beta^-} {}_{69}A_2^{176} \xrightarrow{\gamma} {}_{69}A_3^{176}$</p> <p>Mass number of A is 180 Atomic number of A is 70</p> <p>Alternatively</p> <p>${}_{72}A^{180} \xrightarrow{\alpha} {}_{70}A_1^{176} \xrightarrow{\beta^+} {}_{69}A_2^{176} \xrightarrow{\gamma} {}_{69}A_3^{176}$</p> <p>Mass number of A is 180 Atomic number of A is 72</p>	(a) Binding Energy/nucleon graph	1 1/2	Property	1/2	(b) Finding Atomic number and Mass number of A	1	<p>1/2</p> <p>1/2</p> <p>1/2</p>	<p>3</p>
(a) Binding Energy/nucleon graph	1 1/2								
Property	1/2								
(b) Finding Atomic number and Mass number of A	1								

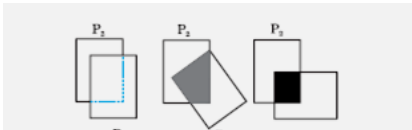
<p>Set1,Q20</p> <p>Set2,Q19</p> <p>Set3,Q22</p>	<table border="1" data-bbox="161 1526 1152 1696"> <tr> <td>Diagram</td> <td>1/2</td> </tr> <tr> <td>Explanation</td> <td>1</td> </tr> <tr> <td>Graph</td> <td>1/2</td> </tr> <tr> <td>Understanding graph using Malus' law</td> <td>1</td> </tr> </table> 	Diagram	1/2	Explanation	1	Graph	1/2	Understanding graph using Malus' law	1		
Diagram	1/2										
Explanation	1										
Graph	1/2										
Understanding graph using Malus' law	1										

When light from an ordinary source passes through a polaroid sheet P_1 , its intensity is reduced by half. When the second polaroid (identical to the first one) is rotated with respect to the first one, the intensity of the light transmitted by the second polaroid varies from zero to maximum.

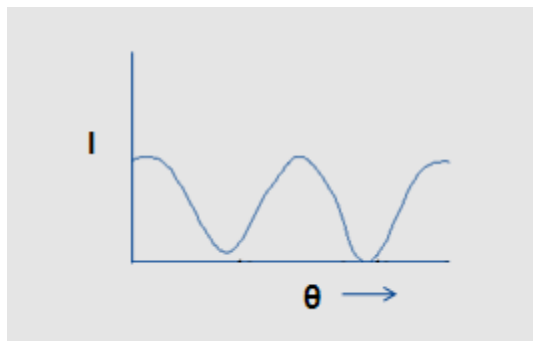

According to Malus's law when the angle between the two polaroids is θ , the intensity of the transmitted light by the second polaroid is given by the relation

$$I = I_0 \cos^2 \theta$$

As θ keep on changes, intensity of the transmitted light by the second polaroid changes.

1/2

1

1

3

Set1,Q21
Set2,Q14
Set3,Q11

- | | |
|---|-----------|
| (a) Calculation of current | 1 |
| (b) Voltage across resistor and capacitor | 1/2 + 1/2 |
| Paradox and its resolution | 1/2 + 1/2 |

(a) Current in the circuit

$$I = \frac{V}{\sqrt{R^2 + \left(\frac{1}{C\omega}\right)^2}}$$

$$I = \frac{220}{\sqrt{100^2 + \left(\frac{1}{\frac{100}{\pi} \times 10^{-6} \times 2\pi \times 50}\right)^2}}$$

$$= \frac{2.2}{\sqrt{2}} \text{ A} = 1.55 \text{ A}$$

1/2

(b) Voltage across the resistor = $100 \times 1.55 \text{ V}$
= 155 volt

1/2

Voltage across the capacitor = $100 \times 1.55 \text{ V}$
= 155 volt

1/2

1/2

Yes

1/2

The sum of the two voltages is greater than 220 V but the voltage across the resistor and the capacitor are not in phase.

1/2

3

	<p>When metal conductor is subjected to a certain potential the electron get accelerated due to electric field. Each electron experiences acceleration for an average time, τ, called the relaxation time. It then undergoes a collision and its velocity again becomes random. The average(drift) velocity of all the electrons contributes to the flow of current.</p> <p>The average velocity of electrons, acquired through their acceleration for a time τ is called drift velocity. $v_d = \frac{eE}{m} \tau$</p> <p>Current density</p> $j = \frac{I}{A}$ $= \frac{neAv_d}{A}$ $= ne \left\{ \frac{eE}{m} \tau \right\}$ $= \left(\frac{ne^2\tau}{m} \right) E$ $\therefore \vec{j} = \sigma \vec{E}$	<p>1</p> <p>$\frac{1}{2}$</p> <p>$\frac{1}{2}$</p> <p>$\frac{1}{2}$</p> <p>$\frac{1}{2}$</p>	<p>3</p>
--	---	--	----------

Section D

<p>Set1,Q23 Set2,Q23 Set3,Q23</p>	<table border="1" style="width: 100%;"> <tr> <td>The qualities displayed by Deepika, Ruchika and the teacher</td> <td style="text-align: right;">2</td> </tr> <tr> <td>Principle of galvanometer</td> <td style="text-align: right;">1</td> </tr> <tr> <td>Shape of the magnets and why is it so designed</td> <td style="text-align: right;">1</td> </tr> </table> <p>a) The values displayed by Deepika and Ruchika are their inquisitiveness for practical knowledge. The teacher displayed concern for the students.</p> <p>b) Principle: When a current passes through a coil, placed in a uniform magnetic field, it experiences a torque.</p> <p>c) The pole pieces of the magnet are given a concave shape. This is done to produce a radial magnetic field.</p>	The qualities displayed by Deepika, Ruchika and the teacher	2	Principle of galvanometer	1	Shape of the magnets and why is it so designed	1	<p>1</p> <p>1</p> <p>1</p> <p>$\frac{1}{2}$</p> <p>$\frac{1}{2}$</p>	<p>4</p>
The qualities displayed by Deepika, Ruchika and the teacher	2								
Principle of galvanometer	1								
Shape of the magnets and why is it so designed	1								

Section E

<p>Set1,Q24 Set2,Q25 Set3,Q26</p>	<table border="1" style="width: 100%;"> <tr> <td>Flux through the flat faces</td> <td style="text-align: right;">1 $\frac{1}{2}$</td> </tr> <tr> <td>Flux through the curved surface</td> <td style="text-align: right;">1</td> </tr> <tr> <td>Net flux</td> <td style="text-align: right;">1</td> </tr> <tr> <td>The charge inside the cylinder</td> <td style="text-align: right;">1 $\frac{1}{2}$</td> </tr> </table>	Flux through the flat faces	1 $\frac{1}{2}$	Flux through the curved surface	1	Net flux	1	The charge inside the cylinder	1 $\frac{1}{2}$		
Flux through the flat faces	1 $\frac{1}{2}$										
Flux through the curved surface	1										
Net flux	1										
The charge inside the cylinder	1 $\frac{1}{2}$										

(ii) Flux through the curved surface = 0
 [As electric field and area vector are perpendicular to each other]

$$\text{Net outward flux} = \pi r^2 E_o + \pi r^2 E_o + 0 = 2\pi r^2 E_o$$

$$\begin{aligned} \text{Charge inside the cylinder} &= \text{Net flux} \times \epsilon_o \\ &= (2\pi r^2 E_o) \times \epsilon_o \\ &= 2\pi \epsilon_o r^2 E_o \end{aligned}$$

OR

Electric field outside the plates	1/2 + 1/2
Electric field between the plates	1/2
Capacitance Expression	1 1/2
Effect on electric field on introducing the dielectric	1
Effect on Capacitance with dielectric	1

(a) Calculation of electric field

(i) Electric field outside the plates: $\frac{\sigma}{2\epsilon_o} + \frac{(-\sigma)}{2\epsilon_o} = 0$ on both the sides of the capacitor. 1/2 + 1/2

(ii) Electric fields between the two plates

$$\text{due to the left plate} = \frac{\sigma}{2\epsilon_o} \text{ towards right}$$

$$\text{due to the right plate} = \frac{\sigma}{2\epsilon_o} \text{ towards right}$$

$$\therefore \text{Net Electric field} = \frac{\sigma}{\epsilon_o} \text{ (towards right)}$$

$$\text{Capacitance, } C = \frac{Q}{V}$$

$$= \frac{Q}{Ed} = \frac{\sigma A}{\left(\frac{\sigma d}{\epsilon_o}\right)}$$

$$= \epsilon_o A/d$$

(b) (i) When a dielectric slab is introduced, the Electric field decreases to $\frac{E}{K} = \frac{\sigma}{K\epsilon_o}$ where K is the dielectric constant. This is because of the (oppositely directed) field due to the polarized dielectric. 1

(ii) Capacitance with dielectric increases by a factor K because the electric field (and hence p.d.) decreases by a factor K. 1

5

5



a) Better Light gathering power and higher resolving power

b)

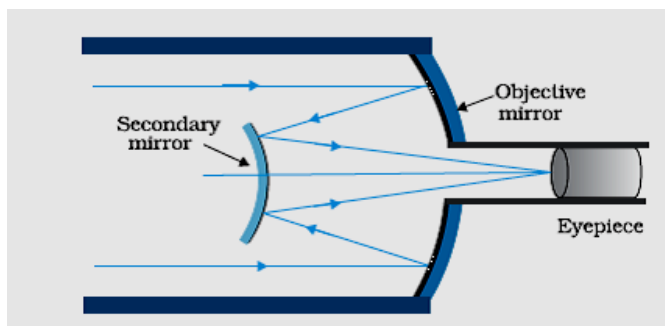

Magnifying power of the telescope is the ratio of the angle subtended at the eye by the final image to the angle subtended by the object at the lens or the eye.

[Also accept if the student just writes $m = \frac{f_o}{f_e}$]

- 1) Larger objective size
 - 2) No spherical aberration,
 - 3) No chromatic aberration,
 - 4) More light gathering power
 - 5) Mounting and polishing is easier
 - 6) More economical
- [any two points]

OR

(a) Diagram	2
(b) Minimum separation	1½
Relation with resolving power	½
Factors by which resolving power can be increased	1

(a)

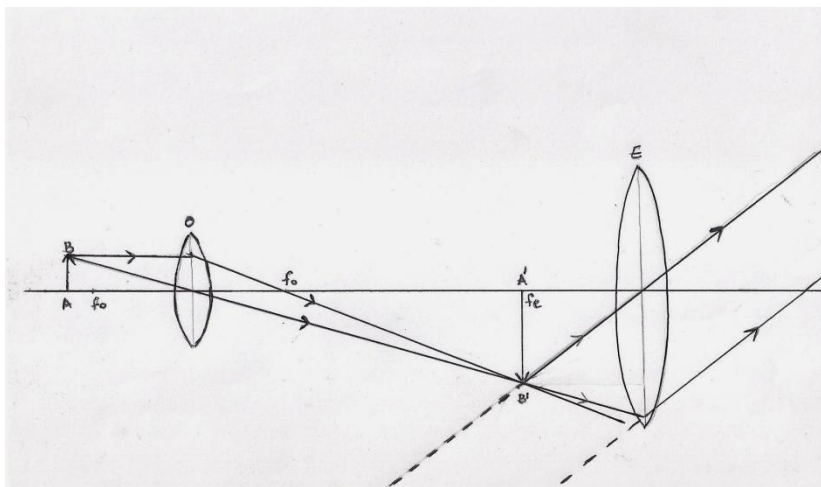

1 + 1

1

1

½ + ½

5

2

[Also accept if the student draws the following diagram]

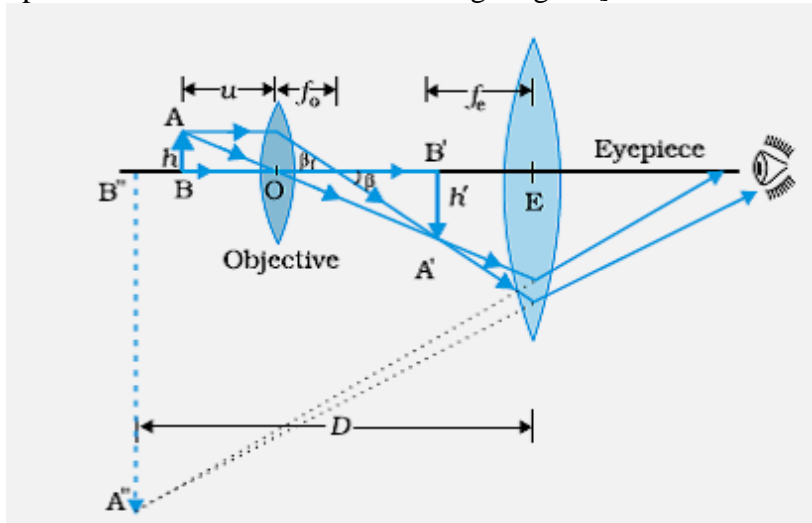

(b) $S = \text{Size of image of a point object in the image plane} = v \left(\frac{1.22 \lambda}{d} \right)$
 Minimum separation between two distinctly seen points in the object plane = $\frac{S}{\text{Magnifying Power}}$

$$= \frac{S}{\left(\frac{v}{f}\right)} = \frac{1.22 f \lambda}{D}$$

[Also give this mark if the student writes

(i) Minimum separation = $\frac{1.22 f \lambda}{D}$

Or (ii) Minimum separation equals the separation at which their images are just resolved

Or (iii) Minimum separation corresponds to 'limit of resolution'.]

$$\text{Resolving power} = \frac{1}{d} = \frac{2\mu \sin \theta}{1.22 \lambda}$$

[Also accept: Resolving power $\propto \frac{1}{(\text{minimum separation})}$]

Resolving power can be increased by

- (i) increasing the aperture of the objective
- (ii) using a medium with higher refractive index
- (iii) by decreasing the wavelength of the light used for illuminating the object

[Any two]

1/2

1

1/2

1

5

Set1,Q26
Set2,Q24
Set3,Q25

(a) Meaning of mutual inductance	1
(b) Expression for the mutual inductance of the arrangement	2
(c) Expression for the emf induced	2

(b) Flux (ϕ_1) associated with S_1 when I_2 current flows through S_2

$$N_1\phi_1 = M_{12}I_2 \text{ -----(1)}$$

The magnetic field due to the current I_2 in S_2 is $\mu_0 n_2 I_2$

$$\begin{aligned} \therefore N_1\phi_1 &= (n_1 l)(\pi r_1^2)(\mu_0 n_2 I_2) \\ &= \mu_0 n_1 n_2 \pi r_1^2 l I_2 \text{ -----(2)} \end{aligned}$$

From (1) and (2), we get

$$M_{12} = \mu_0 n_1 n_2 \pi r_1^2 l$$

(c) Induced emf in coil C_1 due to the change in current through C_2

We have $N_1\phi_1 = M I_2$

For varying currents,

$$N_1 \left(\frac{d\phi_1}{dt} \right) = M \left(\frac{dI_2}{dt} \right)$$

$$\therefore -\varepsilon_1 = M \left(\frac{dI_2}{dt} \right)$$

$$\text{or } \varepsilon_1 = -M \left(\frac{dI_2}{dt} \right)$$

OR

(a) Statement of Ampere's circuital law	1
Derivation of magnetic field B	2
(b) Magnetic field inside the thick wire	1
outside the wire	1/2
Graph	1/2

(a) Ampere's Circuital law states that the line integral of the magnetic field, over a closed loop is equal to μ_0 times the total current passing through the surface enclosed by the loop.

$$\text{Alternatively, } \oint \vec{B} \cdot d\vec{l} = \mu_0 I$$

Let an infinite straight wire carry a current I . We consider a circle of radius r , centered on the wire, and having its plane perpendicular to the wire.

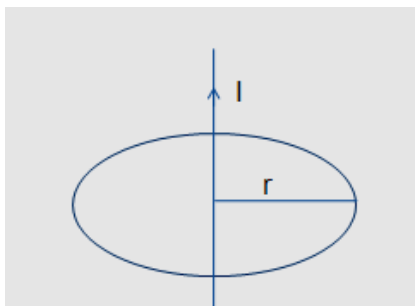

1/2

1/2

1

1/2

1/2

1/2

1/2

5

1

1/2

∴ By Ampere's circuital law,

$$\oint \vec{B} \cdot d\vec{l} = B \cdot 2\pi r = \mu_0 I$$

$$\therefore B = \frac{\mu_0 I}{2\pi r}$$

(b) For $r < a$, we have

$$B \cdot 2\pi r = \mu_0 I_{\text{enclosed}}$$

$$= \mu_0 \left(\frac{\pi r^2}{\pi a^2} \right) I$$

$$= \frac{\mu_0 r^2}{a^2} I$$

$$\therefore B = \frac{\mu_0}{2\pi} \frac{I}{a^2} r$$

For $r > a$

$$B \cdot 2\pi r = \mu_0 I$$

$$\text{or } B = \frac{\mu_0 I}{2\pi r}$$

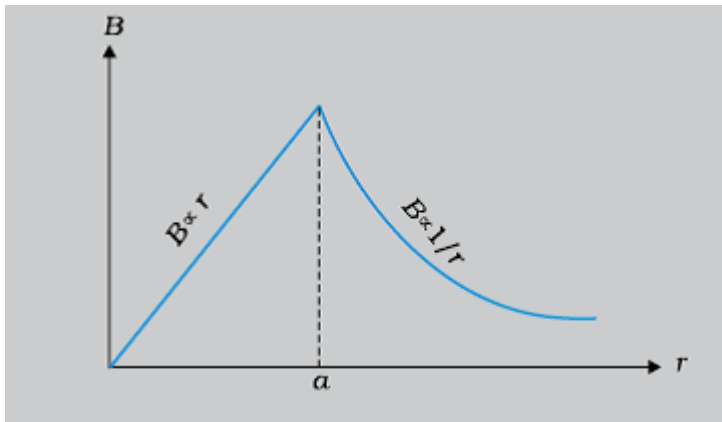

1

1/2

1/2

1/2

1/2

1/2

